



www.fine-tek.com

Intelligent Level Sensor for Pharmaceutical / F&B



PRODUCT INTRODUCTION

PRINCIPLE

The sensor's working principle by sending "scan-frequency", different material emits different frequency, therefore, the sensor will send the switch signal while it's powered by material.

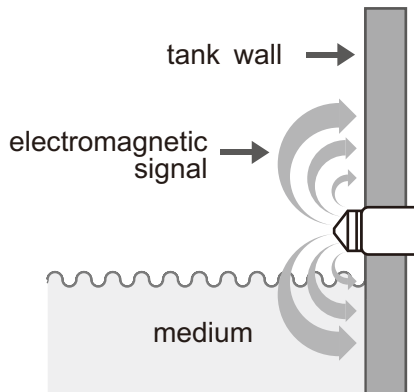

FEATURE

- Easy installation by standard connection with IP67/IP68/IP695 as protection grade.
- Compact design, easy carry; can be installed in narrow space or stringent operation condition.
- The surface roughness (Ra) can be customized and applicable for Chemical & pharmaceutical and food processing industries.
- With magnetic test function to examine wiring and operation condition in real time.
- Durable stainless housing.
- Real time site-control by LED indicators.
- Overcurrent protection detects over current and shut down the output immediately.
- Workable in CIP and SIP cleaning environment.
- Unaffected by foam and viscous medium.
- Applicable to measure the single-point level of liquid, viscous medium and powder medium in the container and pipe; also providing pump dry run protection.
- It provides 2 output signals and the sensitivity can be set independently; which helps detect 2 kinds of medium.
(For instance: Oil and water.)

INSTALLATION DIAGRAM

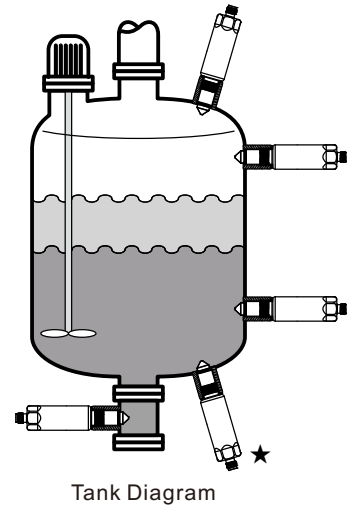

Tank Diagram

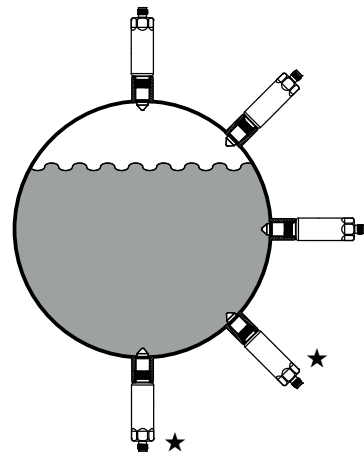

Pipeline Diagram

Top diagram shows the sensors be installed on the container, for instance: monitoring the level or protection pump dry run device.
Below diagram shows the sensors be installed in the pipeline for monitoring the level.

Note: If the medium with strong viscosity, the installation position shows ★ only applicable to certain condition, it may generate failure output signal due the residue be monitored as liquid.

APPLICATION

With high/low level of material in the process tank or pipeline, alarm of empty material or switch output is particularly suitable for application in the following industries:

- Food manufacturing
- Beverage manufacturing
- Pharmaceutical manufacturing.

APPLICABLE MEDIUM FORM

Following form, please kindly choose the medium and corresponded default setting. Always ensure the correct setting and corresponded medium.

Attention!! It may cause failure result or unstable operation condition if the application NOT follow the operation range. ● means you can measure the medium based on FineTek default setting.

	Item	Water Based	Low Moisture/ Sugar Content	Oil Based/ Powder
1	Tap water	●		
2	Seawater	●		
3	Pure water	●		
4	Beer	●		
5	Wine	●		
6	Liquor(40%)		●	
7	Juice (Stock)	●		
8	Juice (Distillate)	●		
9	Milk	●		
10	Yoghurt Drink	●		
11	Vinegar	●		
12	Condensed Milk 7.5%	●		
13	Chocolate(40°C)		●	
14	Syrup		●	
15	Honey		●	
16	Fructose	●		
17	Albumen	●		
18	Yolk		●	
19	Egg(Liquid)	●		
20	Jam(Almond)	●		
21	Jam(Strawberry)	●		
22	Barbecue Sauce	●		
23	Soy Sauce	●		
24	Flour			●
25	Starch			●
26	Cocoa Powder			●
27	Coffee Powder			●
28	Hazelnut Powder(40°C)			●
29	Pepper(Ground)			●
30	Mashed Potatoes			●
31	Creamer(Powder)			●
32	Salt			●
33	Caster Sugar			●
34	Crystal Sugar(Ground)			●
35	Mayonnaise			●
36	Butter		●	
37	Olive Oil			●
38	Palm Oil			●
39	Canola Oil			●
40	Sunflower Oil			●
41	Linseed oil			●
42	Glycerin	●		
43	Mineral Oil(15W40)			●
44	Acetone		●	
45	Methanol	●		
46	Ethanol	●		

STANDARD SPECIFICATIONS

Ambient environment	Water-based media, oil-based media, powder media, dual-level media (such as oil+water), fluid with separation layer (such as bubbles)
Ambient temperature	-40~85°C(-40~185°F)
Process temperature	Max: 100°C (Continuous) while ambient temp.: -40~85°C(-40~185°F) Max: 150°C (Less than 1HR) while ambient temp.: -40~60°C(-40~140°F)
Rated voltage	18VDC~30VDC
Power consumption	Max. 50mA
Over voltage protection	overvoltage category II
Reversal protection	Yes
Switch output (optional)	2 switches: 1 st NO mode and 2 nd NC mode.
Output mode	PNP/NPN (optional)
Switch delay function	<1 second(maximum 60 seconds)
Output load current	Max. 100 mA
Voltage drop	Max. 2.5V
Short-circuit protection	Yes, short-time pulse
Overload protection	Yes
Electric connection	M12 4PIN connector
Wetted material (optional)	SUS316 、SUS316L
Process pressure	-1~40 bar
Contact specification	G1/2
Probe material/surface Roughness	PEEK/Ra<0.8
Housing protection (optional)	IP67/IP68/IP69K (Under water 1meter, IP68 can last for 30 days).
LED Indicator	Yellow LED for starting, Green LED for resetting
Digital communication	Comply with IO Link V1.1, In pending
Standard compliance	IEC61000-4-2, IEC61000-4-4, IEC61000-4-11

Warning:

- 1.The sensor must utilizes FineTek “connector” or “adaptor” then can entitle warranty and working properly and avoid material leaking issue.
2. To achieve IP68/IP69K protection grade, the electrical connection of this device must fit with the M12 electrical cable connection wire in conformity with specifications.

DIMENSIONS

Standard type

Applied for general medium

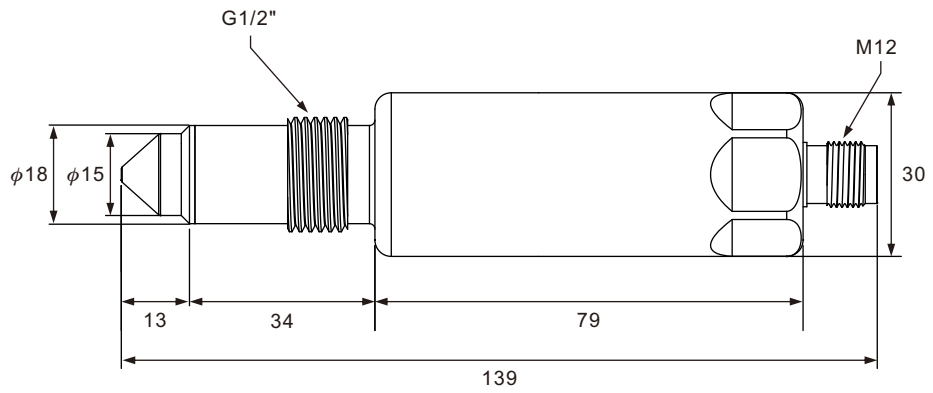

Extension type

Applied for sticky medium or easily build up medium

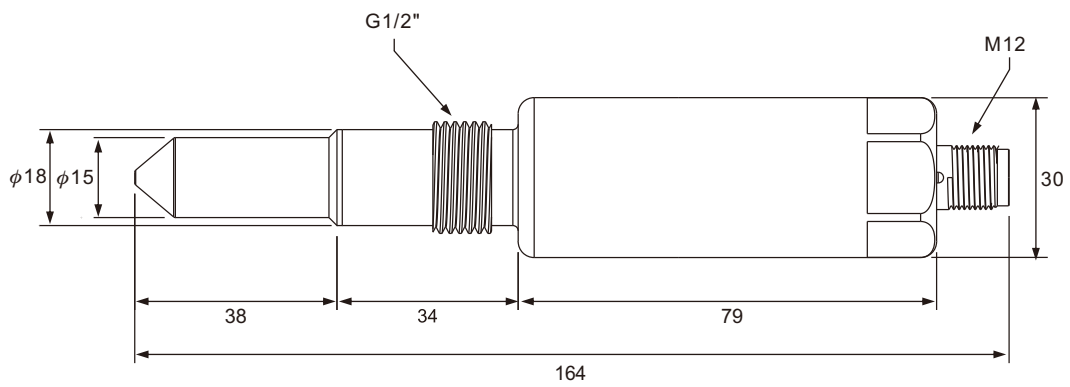

FUNCTIONS

Output mode	Failure mode	Material level	Output	Output signal	LED indicator
PNP	MAX		OUT1	$\square \xrightarrow{<100\mu A} \square$	Green
			OUT2	$\square \xrightarrow{I_L} \square$	Yellow
			OUT1	$\square \xrightarrow{I_L} \square$	Yellow
			OUT2	$\square \xrightarrow{<100\mu A} \square$	Green
	MIN		OUT1	$\square \xrightarrow{I_L} \square$	Yellow
			OUT2	$\square \xrightarrow{<100\mu A} \square$	Green
			OUT1	$\square \xrightarrow{<100\mu A} \square$	Green
			OUT2	$\square \xrightarrow{I_L} \square$	Yellow
NPN	MAX		OUT1	$\square \xrightarrow{<100\mu A} \square$	Green
			OUT2	$\square \xrightarrow{I_L} \square$	Yellow
			OUT1	$\square \xrightarrow{I_L} \square$	Yellow
			OUT2	$\square \xrightarrow{<100\mu A} \square$	Green
	MIN		OUT1	$\square \xrightarrow{I_L} \square$	Yellow
			OUT2	$\square \xrightarrow{<100\mu A} \square$	Green
			OUT1	$\square \xrightarrow{<100\mu A} \square$	Green
			OUT2	$\square \xrightarrow{I_L} \square$	Yellow

- Correspondence output table: OUT 1 sets as NO; OUT 2 sets as NC.
- IL indicates load enabled.

WIRING DIAGRAM

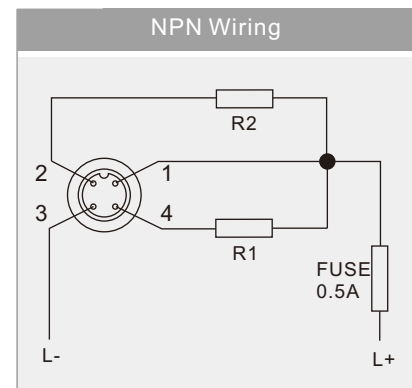
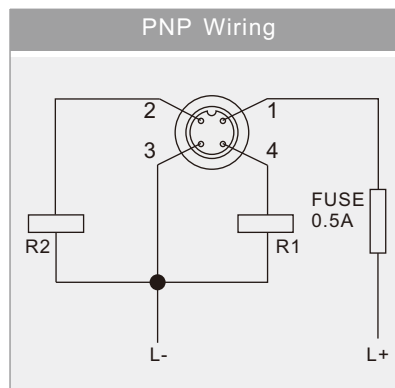
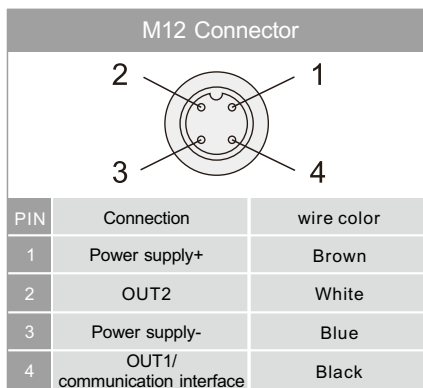

- R1 and R2 indicate the load of OUT1 and OUT2.
 - To protect the sensor from abnormal condition, we strongly recommend to adopt FUSE 0.5A on the power supply circuit.
 - This wire color only represents the property. The actual wire color depends on the connector purchased.
- Note: The accuracy and efficiency can not be guaranteed if using NON-FineTek connector.

ORDER INFORMATION

SIS1 0 0 0 0 - ⁰⁹ MAD ¹³ ¹⁴ ¹⁵ ¹⁶ ¹⁷ ¹⁸ AAA5 1 7 1 3 A ²⁸ ²⁹ ³⁰ ³¹

⁰⁹ Rod type

- A: Standard type
- B: Extension type

¹³ ¹⁴ Output

- 25: PNP
- 26: NPN

¹⁵ Output function

- A: OUT1=NO, OUT2=NC (Default setting)
- B: OUT1=NC, OUT2=NO
- C: OUT1=NO, OUT2=NO
- D: OUT1=NC, OUT2=NC

¹⁶ Medium type

- A: Water-based(Dielectric constant $\epsilon \geq 15$)
- B: Oils, greases, powders (Dielectric constant $\epsilon \leq 15$)
- C: With low water content or viscous
(Dielectric constant $\epsilon \leq 15$)

¹⁷ ¹⁸ Wetted material

- MB: SUS316
- MC: SUS316L

²⁸ ²⁹ ³⁰ ³¹ Rod length

Code	Length
0047	47mm(Standard type)
0072	72mm(Extension type)

ACCESSORIES - THREAD CONNECTOR/ADAPTOR (OPTIONAL)

Thread connector (While sensor welded aside tank wall) specification:

Connection specification	Weld opening	Exterior dimension	Technical parameters		
G 1/2"	φ45mm		Material	Order Code	
			SUS316	SISAM1P-MBA245S101	
			SUS316L	SISAM1P-MCA245S101	
	Application:		<ul style="list-style-type: none"> Structural resistance to pressure 50Bar Reinforced structure of welding beads φ45 		
	φ45mm		Material	Order Code	
			SUS316	SISAM1P-MBA145S101	
			SUS316L	SISAM1P-MCA145S101	
	Application:		<ul style="list-style-type: none"> Structural resistance to pressure 50Bar Reinforced structure of welding beads φ45 With drain hole 		
	φ29mm		Material	Order Code	
			SUS316	SISAM1P-MBA429S101	
			SUS316L	SISAM1P-MCA429S101	
	Application:		<ul style="list-style-type: none"> Structural resistance to pressure 50Bar For storage tank DN25~DN100 		
	φ29mm		Material	Order Code	
			SUS316	SISAM1P-MBA329S101	
			SUS316L	SISAM1P-MCA329S101	
	Application:		<ul style="list-style-type: none"> Structural resistance to pressure 50Bar For storage tank DN25~DN100 With drain hole 		
	φ30mm		Material	Order Code	
			SUS316	SISAM1P-MBA430S101	
SUS316L			SISAM1P-MCA430S101		
Application:		<ul style="list-style-type: none"> Structural resistance to pressure 50Bar For storage tank 			
φ30mm		Material	Order Code		
		SUS316	SISAM1P-MBA330S101		
		SUS316L	SISAM1P-MCA330S301		
Application:		<ul style="list-style-type: none"> Structural resistance to pressure 50Bar For storage tank With drain hole 			

Thread adaptor (for small to large diameter installation) specifications

Female thread specification	Male thread specification	Exterior dimension	Technical parameters	
None	G 1/2"		Material	Order Code
			SUS316	SISAM1P-MBA500S101
			SUS316L	SISAM1P-MCA500S101
			Application: <ul style="list-style-type: none"> The sealing plug is used to close up any hole on the device to prevent leakage. Locking torque 30~50Nm 	
G 1/2"	G 3/4"		Material	Order Code
			SUS316	SISAM1P-MBA600S201
			SUS316L	SISAM1P-MCA600S201
	Application: <ul style="list-style-type: none"> Small to large diameter connector Thread installation for probe connector G 1/2" in G 3/4" 			
	3/4"NPT		Material	Order Code
			SUS316	SISAM1P-MBA600S301
SUS316L			SISAM1P-MCA600S301	
Application: <ul style="list-style-type: none"> Small to large diameter connector Thread installation for probe connector G 1/2" in 3/4"NPT 				

Instructions for using the thread connector and adaptor

- For application related to food and environmental hygiene EHEDG or 3A standards, please comply with requirements stipulated in laws and regulations.
- The 3A certification specified here applies only to the sealed sensor equipped with PEEK probe.
- The surface should not be contaminated or damaged.
- Welding must be performed by authorized professionals.
- Do not install the sensor when it is cooling down during or after welding.
- The material of the welding rod must meet connector and tank (pipeline) standards.
- The welding power and degree of penetration must meet the tank (pipeline) wall thickness and requirements stipulated in laws and regulations.
- Welding should not cause any deformation to the thread connector, which may hinder installation.
- The seal of the thread connector should not be damaged by weld spatter or collision.

Installation of thread connector

1. Drill a hole in the tank/pipeline wall while in installation position based on the external diameter of the “thread connector” with a maximum tolerance of + 0.2mm.
2. Perform dot welding with sufficient strength of 8 points in the junction between the tank/pipeline wall and the “thread connector”, with the same spacing as shown in Figure 1
3. Weld the section between the two points as well as the opposite section. Finish the operation by section based on Figure 2. This is mainly to avoid welding stress and overheating, which may result in deformation of the “thread connector” and affect installation.
4. After welding is completed, there should be enough time for the “thread connector” to cool down before installing the sensor.
5. The screw thread and sealing surface should have no welding traces and damage.
6. If the sealing surface of the “thread connector” is damaged, it can no longer be used. In this case, replace the item and repeat the welding process.

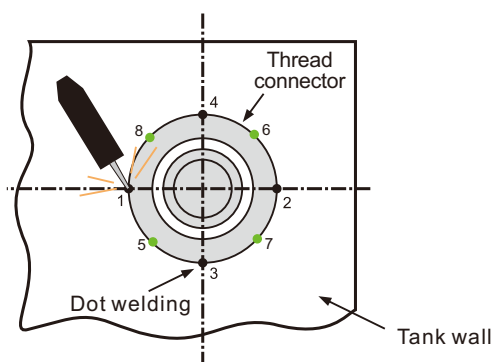

(Figure 1)

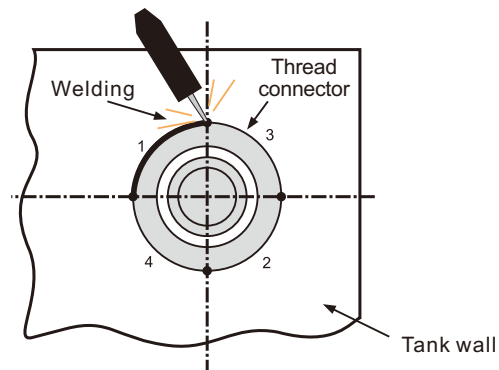

(Figure 2)

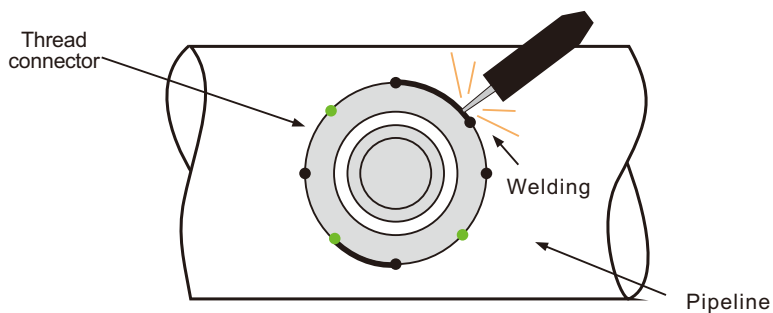

Pipeline welding(Figure 3)

ACCESSORIES-ELECTRICAL CABLE CONNECTOR (OPTIONAL)

M12 ELECTRICAL CABLE CONNECTOR

Order Code: PC312-1231415M01

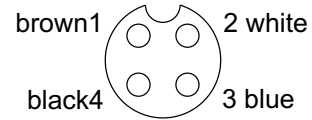
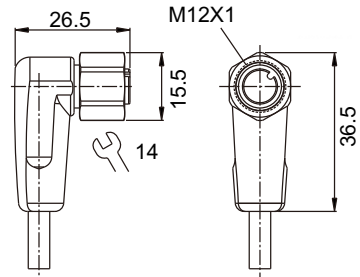

Order Code: PC312-2221410501

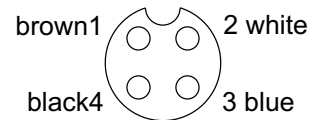
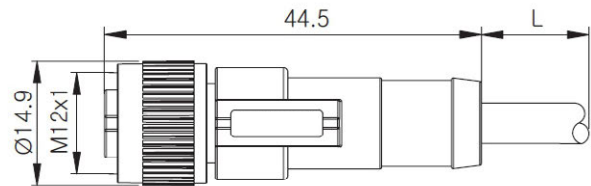

Order Code: PC312-1221415M01

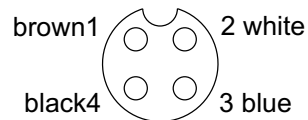
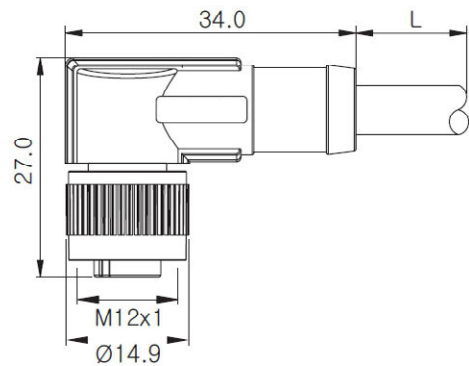

Oder Code: PC312-1222415M01

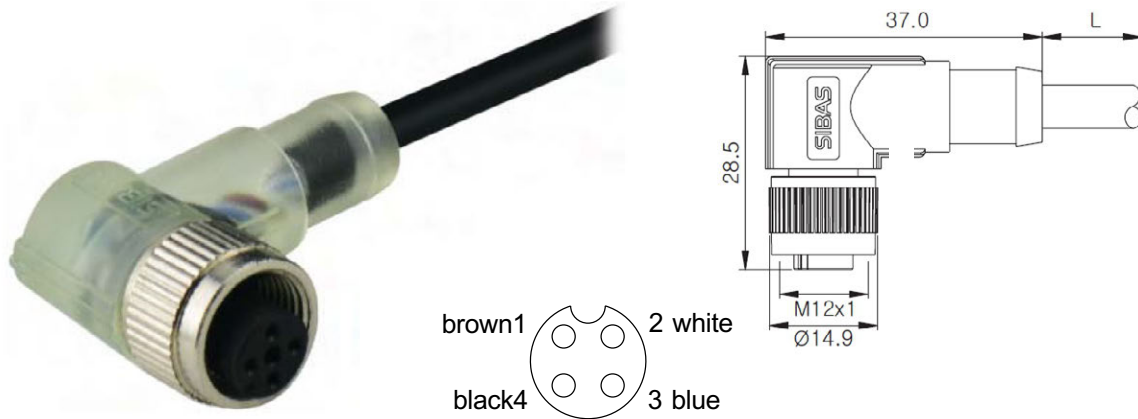

Oder Code: PC312-1232410501



M12 CONNECTOR SPECIFICATIONS

Order Code	Connector type	Cable length	Voltage rating	Current rating	Working temp.	Protection grade	Coating color	LED indicator
PC312-1231415M01	Elbow 90°	5m	250Vac/300Vdc	Max.4A	-25°C~100°C	IP67 IP68 IP69K	Orange	NO
PC312-2221410501	Straight 180°	5m	250Vac	Max.4A	-25°C~80°C	IP67	Blue	NO
PC312-1221415M01	Elbow 90°	5m	250Vac	Max.4A	-25°C~80°C	IP67	Blue	NO
PC312-1222415M01	Elbow 90°	5m	36Vac	Max.4A	-25°C~80°C	IP67	Gray	YES
PC312-1232410501	Elbow 90°	5m	10~36Vac	Max.4A	-25°C~100°C	IP67 IP68 IP69K	Orange	YES

NEW/OLD MODEL NO. COMPARISON TABLE

Old Model NO.	New Model NO.
26-0522-5M	PC312-1231415M01
26-0523-5M	PC312-2221410501
26-0524-5M	PC312-1221415M01
26-0525-5M	PC312-1222415M01
SCA-3371	PC312-1232410501

ACCESSORIES - PROGRAMMER BOX (OPTIONAL)

PROGRAMMER BOX



Order Code	SISAA1X-0004
Exterior dimension(mm)	87X61X50(L XW XH)
Voltage rating	5Vdc(from USB)
Current consumption	Max.500mA
Input interface	Mini USB
Output interface	M12-5C A-Coded
Ambient temperature	-20°C~45°C(-4°F~113°F)
Protection grade	IP20

The programmer box function is to transmit sensor data to PC for reading and editing. Mainly supports calibration and parameter setting for SIS Intelligent Level Sensor.

- Reading current sensor parameter setting.
- Changing sensor parameter setting.
- Adjusting sensor sensitivity of current medium in real time.
- Calibrating current measuring value and do necessary adjustment promptly..

Note: The programmer box is only working while sensor data requiring transmit to PC for reading and editing, not a permanent connection automatic device.

SYSTEM DIAGRAM

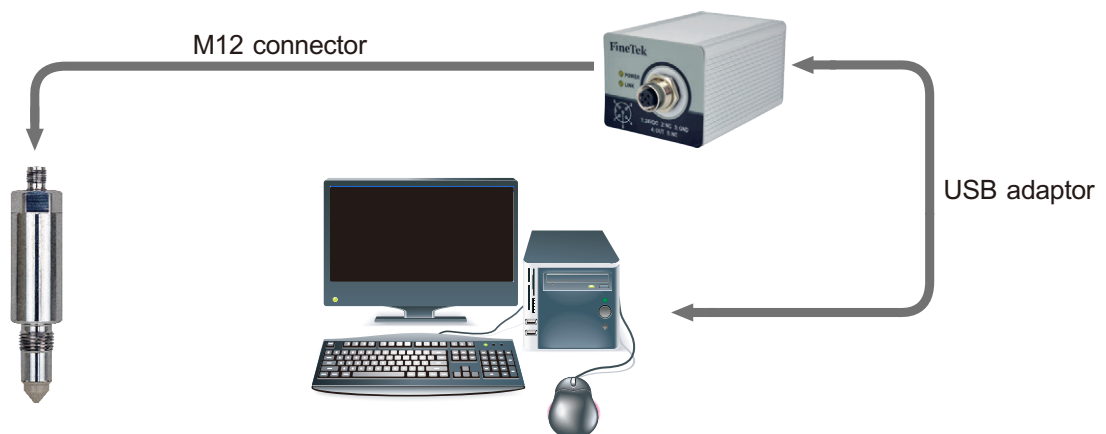

Using M12 connector to link SIS Impedance Spectroscopy Sensor” with programmer box.

Transmitting the sensor data by USB cable from programmer box to PC.

Note: The accuracy and efficiency can not be guaranteed if using NON-FineTek connector.

Global Network

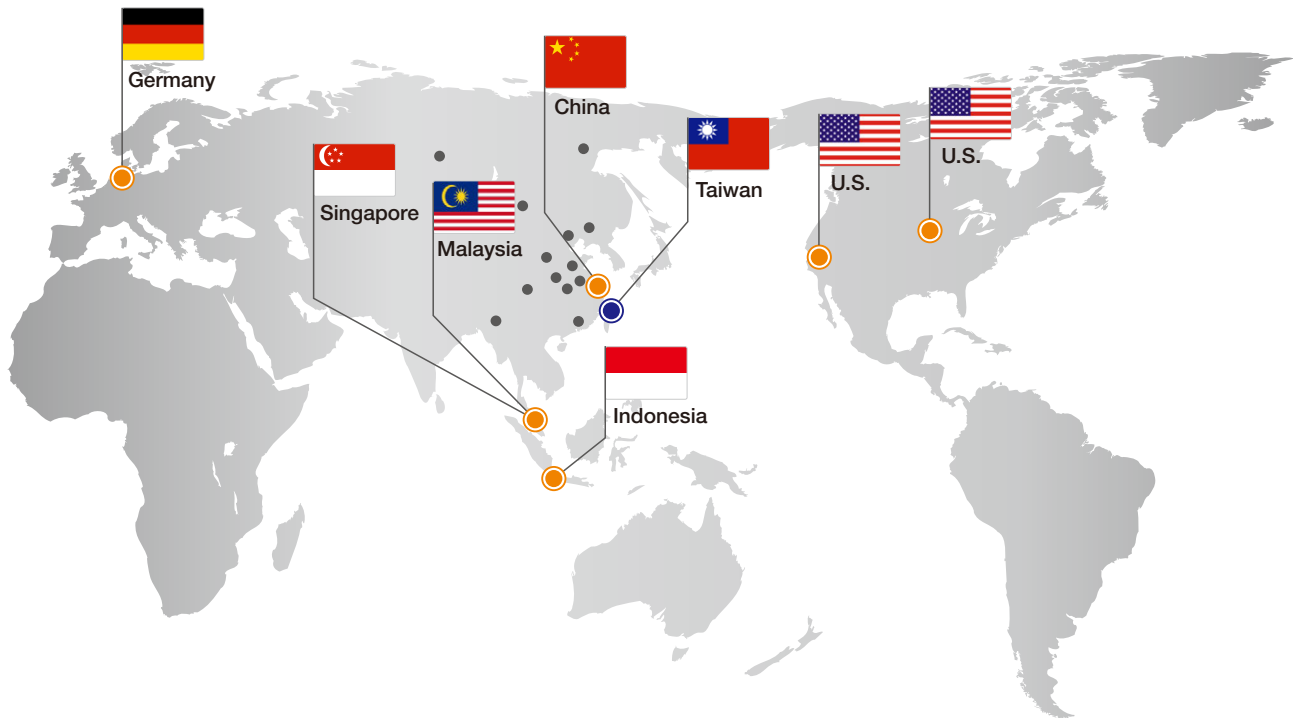

■ Asia

● Taiwan

FineTek Co., Ltd. - Taipei Head Quarter
No.16, Tzuchiang St., Tucheng Industrial Park
New Taipei City 236, Taiwan
TEL: 886-2-2269-6789
FAX: 886-2-2268-6682
EMAIL: info@fine-tek.com

● China

Fine automation Co., Ltd. - Shanghai Factory
No.451 DuHui Rd, MinHang District, Shanghai,
China 201109
TEL: 86-21-6490-7260
EMAIL: info.sh@fine-tek.com

● Singapore

FineTek Pte Ltd. - Singapore Office
No. 60 Kaki Bukit Place, #07-06 Eunos
Techpark 2 Lobby B, Singapore 415979
TEL: 65-6452-6340
EMAIL: info.sg@fine-tek.com

● Indonesia

FineTek Co., Ltd. - Indonesia Office
Ruko Golden 8 Blok H No.38
Gading Serpong, Tangerang, Indonesia
TEL: 62 (021)-2923-1688
EMAIL: info.id@fine-tek.com

● Malaysia

FineTek Co., Ltd. - Malaysia Office
8-05, Plaza Azalea, Persiaran Bandaraya,
Seksyen 14, 40000 Shah Alam, Selangor, Malaysia
TEL: 603-5524-7168
EMAIL: info.my@fine-tek.com

■ North America

● California, U.S.

Aplus Finetek Sensor Inc. - US Office
355 S. Lemon Ave, Suite D, Walnut,
CA 91789
TEL: 1 909 598 2488
FAX: 1 909 598 3188
EMAIL: info@aplusfine.com

● Illinois, U.S.

Aplus Finetek Sensor Inc.
TEL: 1 815 632-3132
FAX: 1 815 716 8464
EMAIL: info@aplusfine.com

■ Europe

● Germany

FineTeK GmbH - Germany Office
Frankfurter Str. 62, OG D-65428
Ruesselsheim, Germany
TEL: +49-(0)6142-17608-0
FAX: +49-(0)6142-17608-20
EMAIL: info@fine-tek.de

● Mütéc Instruments GmbH - Germany Office

Bei den Kämpfen 26
21220 Seevetal-Ramelsloh, Germany
TEL: + 49 (0)4185-8083-0
FAX: + 49 (0)4185-8083-80
EMAIL: muetec@muetec.de



Distributor: