

SYPHON SY SERIES

Technical Data

Material: SS316, SS304 available

Pipe Rating: Sch40S, Sch80S available

Working Pressure & Temperature

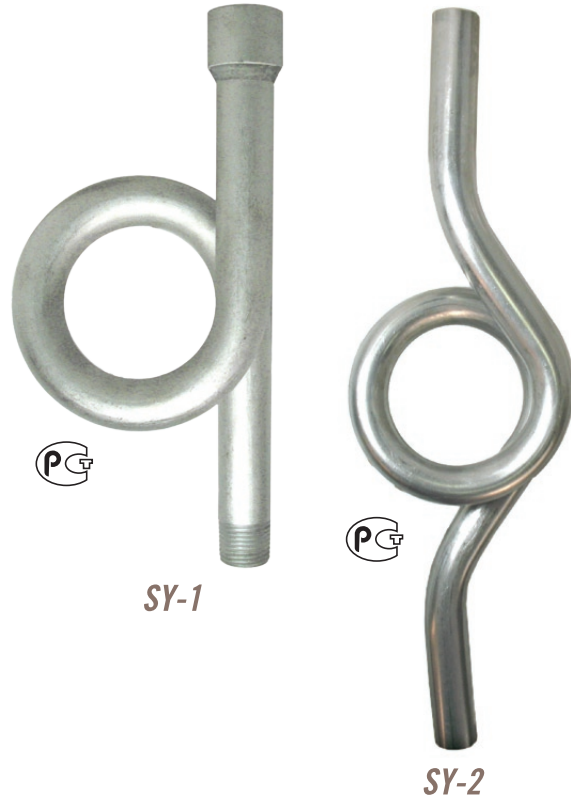
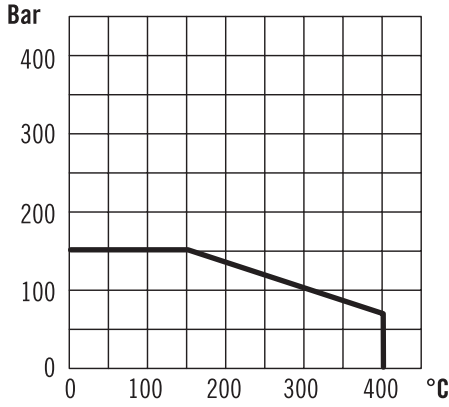

Dimensions

SY-1 Type

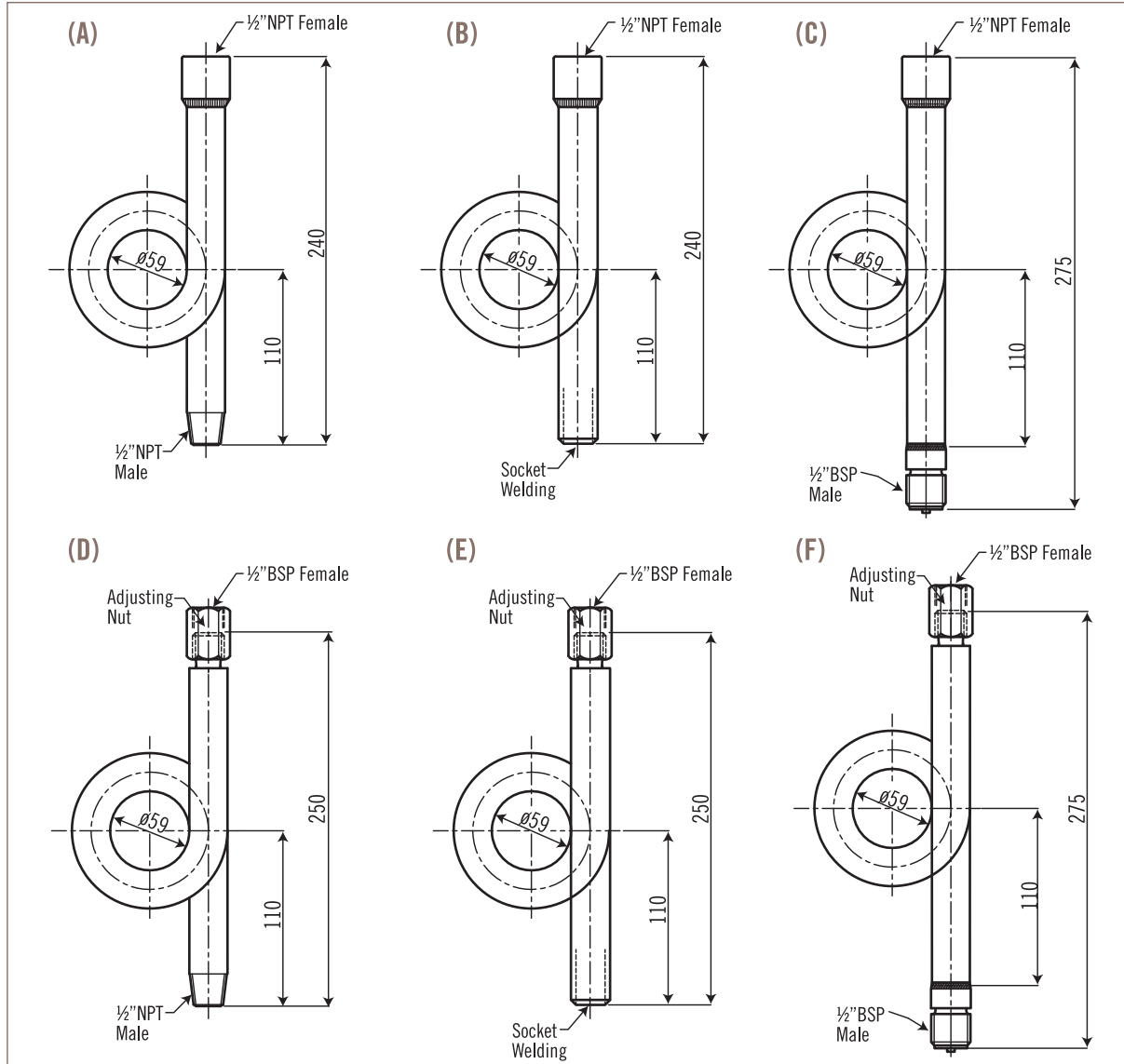

SY-2 Type

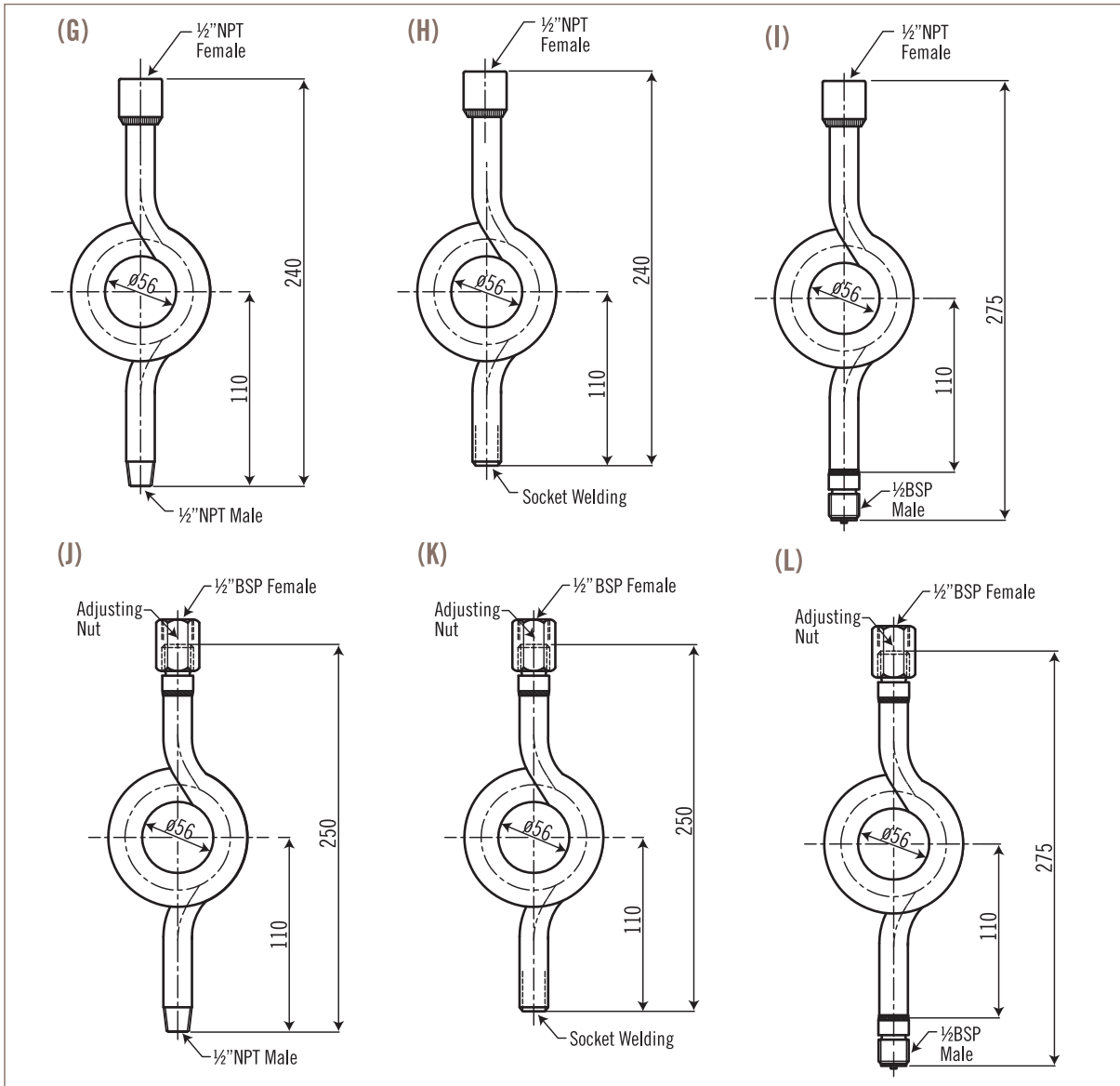

Tube Table

Tube / Material	Max. Temp. (°C)	Max. Press. (Bar)
Sch 40S / SS316	80	250
	120	160
	300	100
	400	80
Sch 80S / SS316	80	300
	120	300
	300	160
	400	100
Sch 100S / SS316	80	400
	120	400
	300	250
	400	160

Ordering Information

SY	Code	Type / Connection Figure	
↓	1-A	SY-1 / A	2-G SY-2 / G
	1-B	SY-1 / B	2-H SY-2 / H
	1-C	SY-1 / C	2-I SY2 - / I
	1-D	SY-1 / D	2-J SY-2 / J
	1-E	SY-1 / E	2-K SY-2 / K
	1-F	SY-1 / F	2-L SY-2 / L
	Option	Please contact manufacturer directly	
↓	Code	Tube Size	
	1	Sch 40S	2 Sch 80S
↓	Code	Tube Type	
		(1) Seam (2) Seamless	
↓	Code	Tube Material	
		(1) SS304 (2) SS316	
SY			